

NUTS

Cage Style

SPRING NUTS

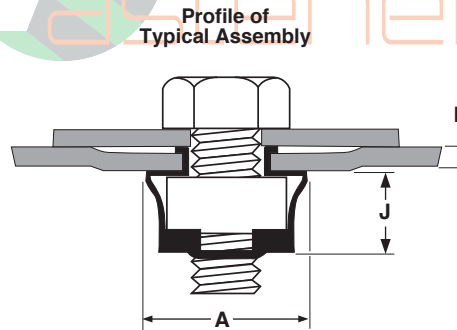
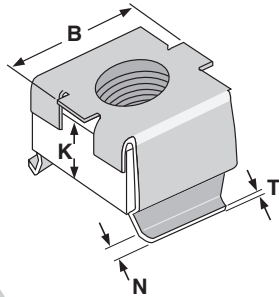

CAGE NUTS													Tinnerman® Palnut	
Screw Size	Part Numbers (Steel)		B		A		J		N		T	K	P	
	Kanebridge	Tinnerman®	Cage Width (Static)		Cage Width (Assembled)		Cage Height		Foot Width		Material Thickness	Nut Thickness	Panel Range	
			Max	Min	Min	Max	Min	Max	Min	Ref	Ref	Max	Min	
6-32	06NCAG 0608NCAG	7931-632	.530	.510	.540	.260	.240	.070	.050	.020	.156	.063	.025	
8-32	08NCAG	7931-832	.530	.510	.531	.260	.240	.070	.050	.020	.156	.063	.025	
8-32	08-064NCAG	7941-832	.530	.510	.475	.265	.235	.070	.050	.020	.156	.105	.064	
10-24	10NCAG	7941-1024	.530	.510	.531	.260	.240	.070	.050	.020	.156	.105	.064	
10-24	10-025NCAG	7931-1024	.530	.510	.475	.265	.235	.070	.050	.020	.156	.063	.025	
10-32	11NCAG	7931-1032	.530	.510	.531	.260	.240	.070	.050	.020	.156	.063	.025	
10-32	11-064NCAG	98579-1032	.530	.510	.525	.260	.240	.070	.050	.020	.156	.105	.064	
10-32	11-093NCAG	7951-1032	.530	.510	.525	.260	.240	.070	.050	.020	.156	.126	.093	
12-24	12NCAG	7941-1224	.530	.510	.531	.260	.240	.070	.050	.020	.156	.105	.064	
1/4-20	14NCAG	7988-1420	.530	.510	.531	.260	.240	.070	.050	.020	.187	.063	.025	
1/4-20	14-064NCAG	98580-1420	.530	.510	.525	.260	.240	.070	.050	.020	.187	.105	.064	
1/4-20	14-093NCAG	7956-1420	.530	.510	.525	.260	.240	.070	.050	.020	.187	.126	.093	
5/16-18	31NCAG	7957-5618	.728	.650	.734	.310	.290	.110	.090	.025	.218	.126	.093	
5/16-18	31-057NCAG	-	.670	.650	.734	.310	.290	.110	.090	.025	.218	.092	.057	
3/8-16	37NCAG	7937-3816	.670	.650	.734	.310	.290	.110	.090	.025	.218	.056	.028	
3/8-16	37-057NCAG	7953-3816	.670	.650	.700	.310	.290	.110	.090	.025	.218	.092	.057	
3/8-16	37-093NCAG	7957-3816	.670	.650	.700	.310	.290	.110	.090	.025	.218	.126	.093	
1/2-13	50NCAG	7968-1213	.880	.860	.828	.420	.400	.120	.100	.025	.304	.092	.059	

Description	A free floating square nut retained within a spring steel cage. The cage has two retaining legs on the same side of the nut, positioned 180° from each other, that hold the nut in place at panel edges or center panel locations.			
Applications/ Advantages	More economical and easier to install than other heavy duty nuts for blind side applications. Free floating nut will compensate for poorly aligned holes. The square cage design keeps the nut from rotating during tightening. Cage nuts are successfully used in heavy duty farm machinery, rail cars, home entertainment components and heating equipment among other applications.			
Material	Steel		Stainless	
	Cage: SAE 1050 - 1065 spring steel	Nut: 6-32 thru 1/4-20: SAE 1108 or equivalent steel 5/16-18 & 3/8-16: SAE 1018 or equivalent steel 1/2-13: SAE 1108 or equivalent steel	Cage: Class 304 3/4-hard stainless steel	Nut: Class 304 J3 stainless steel
Heat Treatment	Parts are quenched from the proper austenitizing temperature directly into a salt bath at between 590°F and 710°F. Parts are held at this quench temperature for a recommended period. Parts are then removed from the salt quenched and air cooled to room temperature.			-
Hardness	Rockwell C 44 - 51			-
Plating	Steel Cage nuts are typically supplied with a zinc plating.		Stainless Cage nuts are usually supplied plain.	

Tinnerman® is a registered trademark of Trans Technology Engineered Components, LLC, Eaton Yale & Towne Inc.. Kanebridge's cage nuts are not manufactured by or connected with the producers of Tinnerman® nuts.