

# HEX CAP SCREWS

## Head & Thread Dimensions

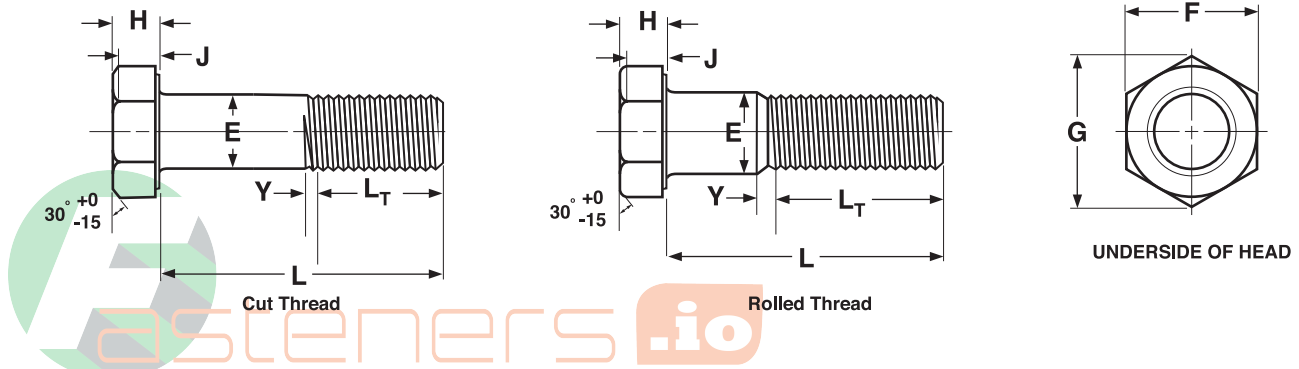

⊥Length of a cap screw is measured from the underhead bearing surface to the extreme end of the screw.

HEX CAP SCREWS																ASME B18.2.1-2012
Nominal or Basic Product Diameter		E		F			G		H			J	L <sub>T</sub>		Y	
		Body Diameter		Width Across Flats			Width Across Corners		Head Height			Wrenching Height	Thread Length		Transition Thread Length	
		Max	Min	Basic	Max	Min	Max	Min	Basic	Max	Min		Min	For Screw Lengths ≤ 6 in.		For Screw Lengths > 6 in.
1/4	0.2500	0.2500	0.2450	7/16	0.438	0.428	0.505	0.488	5/32	0.163	0.150	0.106	0.750	1.000	0.250	
5/16	0.3125	0.3125	0.3065	1/2	0.500	0.489	0.577	0.557	13/64	0.211	0.195	0.140	0.875	1.125	0.278	
3/8	0.3750	0.3750	0.3690	9/16	0.562	0.551	0.650	0.628	15/64	0.243	0.226	0.160	1.000	1.250	0.312	
7/16	0.4375	0.4375	0.4305	5/8	0.625	0.612	0.722	0.698	9/32	0.291	0.272	0.195	1.125	1.375	0.357	
1/2	0.5000	0.5000	0.4930	3/4	0.750	0.736	0.866	0.840	5/16	0.323	0.302	0.215	1.250	1.500	0.385	
9/16	0.5625	0.5625	0.5545	13/16	0.812	0.798	0.938	0.910	23/64	0.371	0.348	0.250	1.375	1.625	0.417	
5/8	0.6250	0.6250	0.6170	15/16	0.938	0.922	1.083	1.051	25/64	0.403	0.378	0.269	1.500	1.750	0.455	
3/4	0.7500	0.7500	0.7410	1-1/8	1.125	1.100	1.299	1.254	15/32	0.483	0.455	0.324	1.750	2.000	0.500	
7/8	0.8750	0.8750	0.8660	1-5/16	1.312	1.285	1.516	1.465	35/64	0.563	0.531	0.378	2.000	2.250	0.556	
1	1.0000	1.0000	0.9900	1-1/2	1.500	1.469	1.732	1.675	39/64	0.627	0.591	0.416	2.250	2.500	0.625	
1-1/8	1.1250	1.1250	1.1140	1-11/16	1.688	1.631	1.949	1.859	11/16	0.718	0.658	0.461	2.500	2.750	0.714	
1-1/4	1.2500	1.2500	1.2390	1-7/8	1.875	1.812	2.165	2.066	25/32	0.813	0.749	0.530	2.750	3.000	0.714	
1-1/2	1.5000	1.5000	1.4880	2-1/4	2.250	2.175	2.598	2.480	15/16	0.974	0.902	0.640	3.250	3.500	0.833	

Tolerance on Length	Nominal Screw Size	Nominal Screw Length				
		Up to 1 in., incl.	Over 1 in. to 2-1/2 in., incl.	Over 2-1/2 in. to 4 in., incl.	Over 4 in. to 6 in., incl.	Longer than 6 in.
	1/4 to 3/8	-0.03	-0.04	-0.06	-0.10	-0.18
	7/16 and 1/2	-0.03	-0.06	-0.08	-0.10	-0.18
	9/16 to 3/4	-0.03	-0.08	-0.10	-0.10	-0.18
	7/8 and 1	....	-0.10	-0.14	-0.16	-0.20
	1-1/8 to 1-1/2	....	-0.12	-0.16	-0.18	-0.22

Gr.2, 18-8 & 316 SS

HEX CAP SCREWS

GRADE-2 HEX CAP SCREW



<b>Description</b>	A low or medium carbon steel, externally threaded mechanical device 1/4" diameter or larger, with a trimmed hex head and a washer face on the bearing surface.
<b>Applications/ Advantages</b>	Economical for use in non-critical applications where the fastener is not subject to extreme temperatures or stress beyond the limits listed herein.
<b>Material</b>	AISI 1006 - 1050 or equivalent steel.
<b>Hardness</b>	<b>1/4 through 3/4 in. diameter, 6 in. and shorter in length:</b> Rockwell B80 - B100. 1/4 through 3/4 in. diameter, over 6 in. in length: Rockwell B70 - B100. 7/8 through 1-1/2 in. diameter, all lengths: Rockwell B70 - B100.
<b>Proof Load</b>	<b>1/4 through 3/4 in. diameter, 6 in. and shorter in length:</b> 55,000 psi. 1/4 through 3/4 in. diameter, over 6 in. in length: 33,000 psi. 7/8 through 1-1/2 in. diameter, all lengths: 33,000 psi.
<b>Yield Strength*</b>	<b>1/4 through 3/4 in. diameter, 6 in. and shorter in length:</b> 57,000 psi. minimum. 1/4 through 3/4 in. diameter, over 6 in. in length: 36,000 psi. minimum. 7/8 through 1-1/2 in. diameter, all lengths: 36,000 psi. minimum.
<b>Tensile Strength</b>	<b>1/4 through 3/4 in. diameter, 6 in. and shorter in length:</b> 74,000 psi. minimum. 1/4 through 3/4 in. diameter, over 6 in. in length: 60,000 psi. minimum. 7/8 through 1-1/2 in. diameter, all lengths: 60,000 psi. minimum.
<b>Elongation*</b>	18% minimum (all diameters)
<b>Reduction of Area*</b>	35% minimum (all sizes)
<b>Plating</b>	See Appendix-A for plating information



HEX CAP SCREW--STAINLESS STEEL, 18-8 & 316



<b>Description</b>	18-8 and 316 stainless steel cap screws are both made from austenitic alloys as described below.
<b>Applications/ Advantages</b>	<b>18-8:</b> Used in products that require general atmospheric corrosion resistance, such as chemical and food-processing equipment. Some chemical environments may require special corrosion resistant materials and precautions. <b>316:</b> The molybdenum content gives this type of stainless even greater corrosion resistance than 18-8 as well as superior strength at high temperatures.
<b>Material</b>	<b>18-8:</b> A cap screw made from one of the following austenitic alloys: 303, 303Se, 304, XM7, all of which are characterized as having a chromium content of 17-19% and nickel content of 8-10%. <b>316:</b> A cap screw made from 316 stainless steel, an austenitic alloy which differs from 18-8 by its molybdenum content (2-3%) and a higher nickel content (10-14%).
<b>Heat Treatment</b>	The austenitic alloys develop their strength through work hardening during the fastener manufacturing process, as seen from the hardness properties below. The only heat treatment normally available on austenitic stainless alloys is annealing, which is done at approximately 1900°F to a dead soft condition and is not normally thermally reversible.
<b>Hardness</b>	<b>1/4 through 5/8 in. diameter:</b> Rockwell B95 - C32 <b>3/4 through 1 in. diameter:</b> Rockwell B80 - C32
<b>Yield Strength*</b>	<b>1/4 through 5/8 in. diameter, 2.25D and longer:</b> 65,000 psi. minimum <b>3/4" (2.25D &amp; longer) &amp; 7/8 through 1 in. diameter (3D &amp; longer):</b> 45,000 psi. minimum
<b>Tensile Strength</b>	<b>1/4 through 5/8 in. diameter, 2.25D and longer:</b> 100,000 - 150,000 psi. <b>3/4" (2.25D &amp; longer) &amp; 7/8 through 1 in. diameter (3D &amp; longer):</b> 85,000 - 140,000 psi.
<b>Elongation in 4D*</b>	<b>1/4 through 5/8 in. diameter:</b> 20% minimum; <b>3/4 through 1 in. diameter:</b> 25% minimum.

D = Nominal diameter of the screw in inches.

\*These properties are tested only on machined specimens when the testing machine cannot provide for full testing of the parts.

\*\*Product standards require the manufacturer's head marking to appear on the top of all cap screws 1/4" diameter and larger. "X" represents one location such a marking may appear.